



# ARIETE

Art. 9075  
Art. 9105  
Art. 9150

 Per tagliare piastrelle in porcellanato, ceramica, marmo e granito. ■ Voltaggi speciali come indicato nella Tabella Dati Tecnici. ■ Trasmissione a cinghia dal motore al disco. ■ Interruttore autostaccante con protezione magnetotermica (a). ■ Raffreddamento con pompa ad immersione e rubinetto di regolazione flusso (b). ■ Gruppo motore scorrevole su quattro carrucole in ferro registrabili (c), ed inclinabile per tagli jolly (45°) (d). ■ Testa basculante con possibilità di bloccare l'altezza desiderata (e) ■ Doppio squadra per tagli lineari e diagonali (f). ■ Squadretto di supporto (h). ■ Piano di taglio largo cm 52. ■ Gambe retraibili con 2 ruote di trasporto (m).

**PARTICOLARI E ACCESSORI SU RICHIESTA:** ■ Prolunga laterale per grandi formati con fermi registrabili (g). ■ Dischi diamantati Ø 300 o Ø 350 specifici per porcellanato, marmo e granito.

 ■ Suitable for cutting porcelain, ceramic, marble and granite tiles. ■ Special voltage ratings available as indicated in the specifications table. ■ Belt driven system. ■ Cutoff switch with thermal cutout (a). ■ Cooling by water pump and flow governor cock (b). ■ Motor unit slides on four adjustable iron pulleys (c). 45° jolly cuts (d). ■ Swinging head can be locked at the desired height (e). ■ Square for linear and diagonal cuts (f). ■ Support square (h). ■ Cutting table width cm 52. ■ Rear feet with 2 wheels (m).

**PARTS AND ACCESSORIES ON REQUEST:** ■ Side extension for big tiles (g). ■ Special Ø 300 or Ø 350 diamond blades for porcelain, marble and granite.

 ■ Pour couper les carrelages grès cérame, céramique, marbre et granit. ■ Voltages spéciaux ainsi qu'il est indiqué aux Tableaux des Données Techniques. ■ Courroie de transmission du moteur au disque. ■ Interrupteur à autodéclenchement avec protection magnétothermique (a). ■ Refroidissement par pompe immergée et robinet de réglage du flux (b). ■ Groupe moteur coulissant sur quatre réas réglables en fer (c). ■ Inclinable pour coupes jolly (45°) (d). ■ Tête basculante avec possibilité de bloquer la hauteur souhaitée (e). ■ Equerre à coupes linéaires et diagonales (f). ■ Petite équerre de support pour coupes diagonales (h). ■ Surface de coupe de 52 cm de large. ■ Pattes arrière avec 2 roues (m).

**PIÈCES ET ACCESSOIRES SUR DEMANDE:** ■ Rallonges latérales pour de grands formats (g). ■ Disques diamantés Ø 300 ou Ø 350 spécifiques pour grès cérame, marbre et granit.







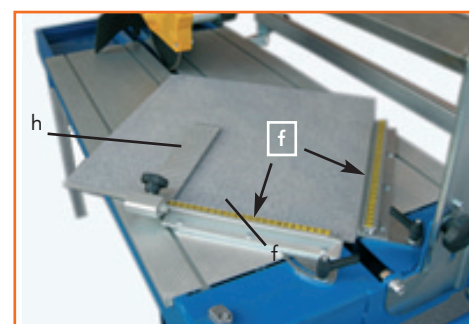
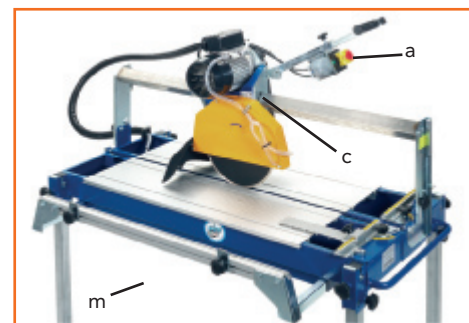
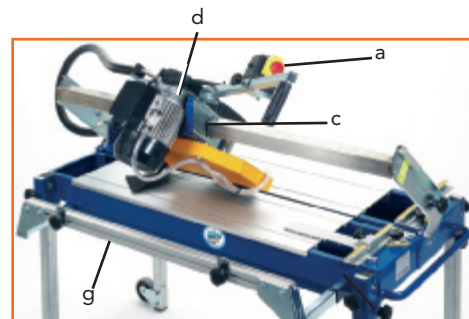

 ■ Zum Schnitt von Fliesen aus Feinsteinzeug, Keramik, Marmor und Granit. ■ Spezialspannungen gemäß Angaben in der Tabelle der technischen Daten. ■ Riemenantrieb vom Motor zur Scheibe. ■ Selbstausschalter mit Thermomagnetschutz (a). ■ Kühlung mit Tauchpumpe und Durchflussregelhahn (b). ■ Schiebe-Motorgruppe auf vier einstellbaren Eisenrollen (c). Schrägstellbar für 45°-Schnitte "Jolly" (d). ■ Schwingkopf, der auf der gewünschten Höhe angehalten werden kann (e). ■ Winkelkopf für Linear und Diagonalschnitte (f). ■ Breite Schnittfläche 52 cm. ■ Hintere Füße mit 2 Rädern (m).

**EINZELTEILE UND ZUBEHÖR AUF ANFRAGE:**

■ Haltewinkel für Diagonalschnitte. ■ Seitliche Verlängerung für große Formate (g).

■ Diamantscheiben Ø 300 oder Ø 350 für Feinsteinzeug, Marmor und Granit.



DATI TECNICI		SPECIFICATIONS		DONNÉES TECHNIQUES		TECHNISCHE DATE	
	HP	W	VOLTS	HZ	RPM	IP	
	2,5	1.850	230/240	50	2.800	55	
	2,0	1.490	110	50	2.800	55	
	2,5	1.850	220	60	3.360	55	
	2,0	1.490	120	60	3.360	55	
		Ø EXT mm 300 / 12"	mm 350 / 14"		cm 11 / 4" Ø mm 300 / 12"		
		Ø INTmm 25,4 / 1"	mm 25,4 / 1"		cm 13 / 5" Ø mm 350 / 14"		
	Art.9075 cm 75 / 30"		cm 68 / 26"		cm 53x53 / 20"X20"		
	Art.9105 cm105 / 41"		cm105 / 41"		cm 70x70 / 27"X27"		
	Art.9150 cm150 / 59"		cm150 / 59"		cm 105x105 / 41"X41"		
	2 PZ		Art.9075 cm 125x90x92 / 50" x 36" x 37"		Kg 65		
			Art.9105 cm 145x90x92 / 57" x 36" x 37"		Kg 82		
			Art.9150 cm 200x90x92 / 79" x 36" x 37"		Kg 89		